

# Document made available under the Patent Cooperation Treaty (PCT)

International application number: PCT/IL05/000140

International filing date: 04 February 2005 (04.02.2005)

Document type: Certified copy of priority document

Document details: Country/Office: US  
Number: 60/566,079  
Filing date: 29 April 2004 (29.04.2004)

Date of receipt at the International Bureau: 09 May 2005 (09.05.2005)

Remark: Priority document submitted or transmitted to the International Bureau in compliance with Rule 17.1(a) or (b)



World Intellectual Property Organization (WIPO) - Geneva, Switzerland  
Organisation Mondiale de la Propriété Intellectuelle (OMPI) - Genève, Suisse

PA 1284501

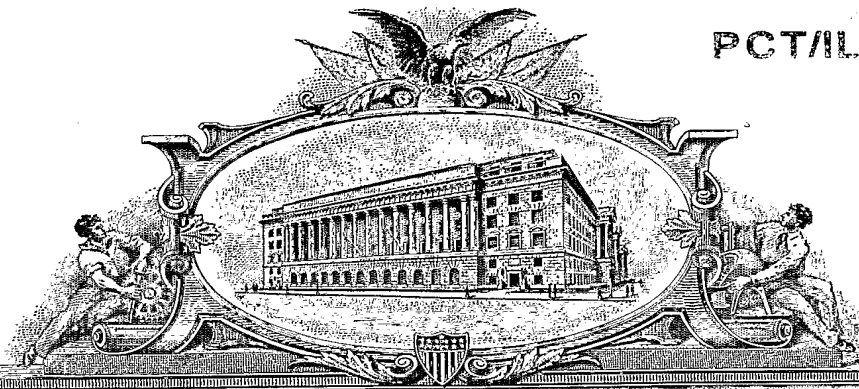

**THE UNITED STATES OF AMERICA**

**TO ALL TO WHOM THESE PRESENTS SHALL COME:**

**UNITED STATES DEPARTMENT OF COMMERCE**

**United States Patent and Trademark Office**

**February 14, 2005**

**THIS IS TO CERTIFY THAT ANNEXED HERETO IS A TRUE COPY FROM THE RECORDS OF THE UNITED STATES PATENT AND TRADEMARK OFFICE OF THOSE PAPERS OF THE BELOW IDENTIFIED PATENT APPLICATION THAT MET THE REQUIREMENTS TO BE GRANTED A FILING DATE UNDER 35 USC 111.**

**APPLICATION NUMBER: 60/566,079**

**FILING DATE: April 29, 2004**

**By Authority of the  
COMMISSIONER OF PATENTS AND TRADEMARKS**



*Trudie Wallace*  
**TRUDIE WALLACE**

**Certifying Officer**

16698 U.S. PTO

29/04 '04 THU 20:05 FAX 972 3 9215383

FENSTER & CO

004

Please type a plus sign (+) inside this box

PTO/SB/16 (5-03)  
Approved for use through 4/30/2003. OMB 0851-0032  
U.S. Patent and Trademark Office, U.S. DEPARTMENT OF COMMERCE  
Under the Paperwork Reduction Act of 1995, no persons are required to respond to a collection of information unless it displays a valid OMB control number.

# PROVISIONAL APPLICATION FOR PATENT COVER SHEET

This is a request for filing a PROVISIONAL APPLICATION FOR PATENT under 37 CFR 1.53(c).

22264 U.S. PTO  
60/566079



| INVENTOR(S)   |  |   |  |   |       |
|---|--|---|--|---|-------|
| Given Name (first and middle [if any])  |  | Family Name or Surname  |  | Residence<br>(City and either State or Foreign Country)       |       |
| Omer  |  | EINAV   |  | Kfar-Monash, Israel   |       |
| <input type="checkbox"/> Additional inventors are being named on the _____ separately numbered sheets attached hereto                   |  |   |  |   |       |
| TITLE OF THE INVENTION (280 characters max)<br>FINE MOTOR CONTROL REHABILITATION  |  |   |  |   |       |
| Direct all correspondence to: CORRESPONDENCE ADDRESS  |  |   |  |   |       |
| <input type="checkbox"/> Customer Number  |  | <input type="text"/>  |  | <input type="text"/>  |       |
| OR Type Customer Number here  |  |   |  |   |       |
| <input checked="" type="checkbox"/> Firm or Individual Name   |  | Roy N. Envall, Jr.  |  |   |       |
| Address   |  | c/o Anthony Castorina   |  |   |       |
| Address   |  | 2001 Jefferson Davis Highway, Suite 207   |  |   |       |
| City  |  | Arlington   |  | State   | VA    |
| Country   |  | U.S.A.  |  | ZIP   | 22202 |
|   |  | Telephone (703) 415-1681  |  | Fax (703) 415-4864  |       |
| ENCLOSED APPLICATION PARTS (check all that apply)   |  |   |  |   |       |
| <input checked="" type="checkbox"/> Specification   |  | Number of Pages   |  | <input type="text" value="18"/>                               |       |
| <input checked="" type="checkbox"/> Drawing(s)  |  | Number of Sheets  |  | <input type="text" value="4"/>                                |       |
| <input type="checkbox"/> Application Data Sheet.  |  | See 37 CFR 1.76   |  | <input type="checkbox"/> CD(s), Number <input type="text"/>   |       |
| <input type="checkbox"/>  |  |   |  | <input type="checkbox"/> Other (specify) <input type="text"/> |       |
| METHOD OF PAYMENT OF FILING FEES FOR THIS PROVISIONAL APPLICATION FOR PATENT (check one)  |  |   |  |   |       |
| <input checked="" type="checkbox"/>   |  | Applicant claims small entity status. See 37 CFR 1.27.  |  | FILING FEE AMOUNT (\$)  |       |
| <input type="checkbox"/>  |  | A check or money order is enclosed to cover the filing fees   |  | <input type="text" value="\$80.00"/>                          |       |
| <input checked="" type="checkbox"/>   |  | The Director is hereby authorized to charge filing fees or credit any overpayment to Deposit Account Number |  | <input type="text" value="03-3419"/>                          |       |
| <input type="checkbox"/>  |  | Payment by credit card. Form PTO-2038 is attached.  |  |   |       |
| The invention was made by an agency of the United States Government or under a contract with an agency of the United States Government. |  |   |  |   |       |
| <input checked="" type="checkbox"/>   |  | No.   |  |   |       |
| <input type="checkbox"/>  |  | Yes, the name of the U.S. Government agency and the Government contract number are: _____                   |  |   |       |

Respectfully submitted,

Date

SIGNATURE

REGISTRATION NO.   
(if appropriate)  
Docket Number:

TYPED or PRINTED NAME **Maier Fenster**

(703) 415-1581

TELEPHONE

## USE ONLY FOR FILING A PROVISIONAL APPLICATION FOR PATENT

This collection of information is required by 37 CFR 1.51. The information is used by the public to file (and by the PTO to process) a provisional application. Confidentiality is governed by 35 U.S.C. 122 and 37 CFR 1.14. This collection is estimated to take 8 hours to complete, including gathering, preparing, and submitting the complete provisional application to the PTO. Time will vary depending upon the individual case. Any comments on the amount of time you require to complete this form and/or suggestions for reducing this burden, should be sent to the Chief Information Officer, U.S. Patent and Trademark Office, U.S. Department of Commerce, P.O. Box 1450, Alexandria, VA 22313-1460. DO NOT SEND FEES OR COMPLETED FORMS TO THIS ADDRESS. SEND TO: Mail Stop Provisional Application, Commissioner for Patents, P.O. Box 1450, Alexandria, VA 22313-1450.

If you need assistance in completing the form, call 1-800-PTO-9199 and select option 2.

P18SMALL/REV05

414/04032

**FINE MOTOR CONTROL REHABILITATION****RELATED APPLICATIONS**

This application claims the benefit under 119(e) of a US provisional application serial number 60/542,022, filed February 5, 2004, by inventor Omer Einav et al., and US provisional application filed on even date, titled "Neuromuscular Stimulation", attorney docket number 414/04031, the disclosure of both applications are incorporated herein by reference.

**FIELD OF THE INVENTION**

The present invention relates to method and apparatus for rehabilitation, for example for eating and writing.

10

**BACKGROUND OF THE INVENTION**

Strokes, accidents and other medical conditions can cause a person to lose the ability to control fine motor actions, for example, those required for handwriting and for eating with a fork and spoon. During a lengthy rehabilitation process, a patient is taught anew to control the limbs.

15

While many rehabilitation methods have been developed, for various reasons patients do not keep to the methods and/or for other reasons do not reassume a reasonable level of control.

**SUMMARY OF THE INVENTION**

A broad aspect of some embodiments of the invention relates to rehabilitation of fine motor control, for example using a finger-manipulated object. In an exemplary embodiment of the invention, the position and/or orientation and/or force on the object are reported to a controller and/or are set by the controller. Optionally, the object is used in a real world setting. Optionally, one or more gross-motor movements of the patient are limited or are rehabilitated simultaneously with the fine motor control.

25

A broad aspect of some embodiments of the invention relates to rehabilitation in which fine motor and gross motor control are rehabilitated simultaneously through the use of a single integrated device. Optionally, positional feedback or positional control is provided by the device to a controller and/or a patient.

30

An aspect of some embodiments of the invention relates to a fine-motor control rehabilitation device, for example, a pen, which is used for emulating and/or as part of real-world activities, such as writing, while allowing the rehabilitation device to apply force to the patient's hand (or other fine motor control source). Optionally, the applied force can be applied to guide the pen in a desired manner, or constrain its movement. Optionally, the device is relocatable with respect to a real-world activity location, for example a table. Optionally, gross

414/04032

motion of a patient's limb is prevented, controlled and/or monitored using a suitable means attached to a user's arm.

In an exemplary embodiment of the invention, such a pen (or any other rehabilitation device) is movable in several degrees of freedom, for example, orientation and planar position. 5 Optionally motion along the pen axis is supported as well. Optionally, motion is limited, for example by design, to the type of motion needed for the rehabilitation task.

Optionally, motion of the pen can be set or constrained by a rehabilitation system. Alternatively or additionally, such motion is measured or assisted by a rehabilitation system. 10 Optionally, the pen includes one or more pressure sensors to determine a particular grip of the pen. Optionally, the pen includes one or more feedback points, for example, small vibrators, which allow a rehabilitation system to provide feedback to a user.

In an exemplary embodiment of the invention, the pen moves in a plane of a table. 15 Optionally, the pen is attached to the table, for example, being held from beneath the table. Alternatively, the pen is held from above the table. Optionally, the pen is mounted on a positioning system which can be moved and attached at various positions relative to a particular table or relative to other tables.

In an exemplary embodiment of the invention, the table includes means for sensing the pen usage, for example a pressure sensor, a tablet computer or other pen-detecting means 20 known in the art, for example position and orientation sensors. Optionally, one or more images may be projected on the table, for example from below (e.g., a transparent table) or from above, or shown using the table as an active display.

In an exemplary embodiment of the invention, the pen is mounted on a ball joint which allows spherical motion of the pen. 25 Optionally, the pen includes an axial linear joint, for radial motion. Optionally, the ball joint is mounted on an X-Y table.

An aspect of some embodiments of the invention relates to a system for rehabilitation 30 of eating. Optionally, the rehabilitation system includes rehabilitation of fine motor control involved in manipulating a utensil and also rehabilitation of gross motor control involved in moving the utensil (e.g., from a plate to a mouth). Optionally, rehabilitation of the mouth and/or coordination of the mouth and hand, are also provided. In an exemplary embodiment of the invention, an eating utensil is held by the system in the air and can be moved over a path from a food container (e.g., a plate) to a user's mouth. Optionally, the rehabilitation system or a user can move the food container, so as to provide multiple rehabilitation situations in a session.

414/04032

Optionally, the rehabilitation system can feed a user automatically and/or complete incomplete user motions. In an exemplary embodiment of the invention, a patient is rehabilitated during daily activities, such as eating. Optionally, the rehabilitation system can detect the state of a mouth, for example whether it is open or closed. Optionally, the rehabilitation system can detect dropping of food, for example dropping from the utensil or from the mouth. Optionally, system includes a camera and suitable image processing for the detection of food dropping.

In an exemplary embodiment of the invention, a rehabilitation system is provided which supports other fine motor tasks, for example, sorting and assembly. Optionally in such applications, the utensil held is a finger of the patient himself, for example, using a short rubber sleeve or ring that fits on a finger.

There is thus provided in accordance with an exemplary embodiment of the invention, apparatus for rehabilitation, comprising:

a utensil adapted to be hand held and manipulated using fingers and be used in a real world task;

a fine motion mechanism coupled to said utensil and adapted to apply force to said utensil, sufficient to move said utensil.

There is also provided in accordance with an exemplary embodiment of the invention; apparatus for rehabilitation, comprising:

a utensil;

a fine motion mechanism adapted to move said utensil in at least three degrees of freedom; and

a gross motion mechanism adapted to move said fine motion mechanism, in at least 2 degrees of freedom.

There is also provided in accordance with an exemplary embodiment of the invention; pen rehabilitation apparatus, comprising:

a surface;

a pen extending up from the surface; and

a motion mechanism adapted to change the orientation of the pen, under the surface.

### BRIEF DESCRIPTION OF THE FIGURES

Non-limiting embodiments of the invention will be described with reference to the following description of exemplary embodiments, in conjunction with the figures. The figures are generally not shown to scale and any sizes are only meant to be exemplary and not necessarily limiting. In the figures, identical structures, elements or parts that appear in more

414/04032

than one figure are preferably labeled with a same or similar number in all the figures in which they appear, in which:

Fig. 1 is a schematic block diagram of a fine motor control rehabilitation system, in accordance with an exemplary embodiment of the invention;

5 Fig. 2 is a perspective view of a semi-portable pen-type rehabilitation system, in accordance with an exemplary embodiment of the invention;

Fig. 3 is a detailed view of a fine motion mechanism for the pen of Fig. 2, in accordance with an exemplary embodiment of the invention;

10 Fig. 4 is a detailed view of an under-the-table pen motion mechanism, in accordance with an exemplary embodiment of the invention; and

Fig. 5 is a perspective view of an eating rehabilitation system, in accordance with a n example embodiment of the invention.

#### DETAILED DESCRIPTION OF EXEMPLARY EMBODIMENTS

##### OVERVIEW

15 Fig. 1 is a schematic block diagram of a fine motor control rehabilitation system 100, in accordance with an exemplary embodiment of the invention.

A patient 128 to be rehabilitated holds a utensil 101, for example a pen or a fork. The rehabilitation activity generally includes fine motor motion of utensil 101 relative to a reference 103 (e.g., a table) and one or more targets 105 (e.g., the table, a plate, a mouth),  
20 which may serve as reference 103. A support structure 107 is optionally provided so that system 100 can move utensil 101, or resist motion thereof. The rehabilitation process is optionally managed by a controller 102 which optionally receives input from various sensors and/or generates movement commands. In a particular class of rehabilitation activities, system 100 allows motion of utensil 101 only within certain ranges of positions and/or orientations.  
25 Exceeding these ranges, as detected by the sensors, may, for example, increase resistance to motion or generate an audio or visual feedback.

For fine motor rehabilitation, a fine motor mechanism 110 is provided, which for example, moves utensil 101, applies force thereto and/or measures force applied thereto. More complex control can be applied as well, for example, assisting motion by patient 128 can  
30 include of sensing motion and then applying force in the direction of that motion.

For combined fine and gross-motor rehabilitation, a gross-motion mechanism 108 is provided, which allows/supports/detects gross motion of the utensil.

414/04032

Optionally, one or more target sensors 106 are provided, which generate signals indicative of the condition of the target (e.g., mouth open, pressure level from utensil) and/or proximity of the utensil to the target (e.g., using absolute or relative measurement).

Optionally, one or more fumble sensors 104 are provided, which generate signals  
5 indicative of a failure to use utensil 101 correctly. In one example, a camera detects food falling off of a fork. In another example, a camera detects ink blotches caused by a pen being used incorrectly.

Optionally, one or more grip sensors 112 are provided, which generate signals regarding the quality or other properties of the gripping of utensil 101 by patient 128. In one  
10 example, a pen includes pressure sensors which indicate points along the pen where pressure is being applied by a hand and/or the pressure level.

Optionally, a task is structured using a display provided to the user using a display 114. In one example an image is projected onto reference 103 (and optionally serves as a target). In another example, one or more of the targets is a display object.

Optionally, one or more utensil sensors 116 are provided, for generating feedback on  
15 the location and/or orientation of the utensil. In some cases, for example in a pen, the fine motion mechanism may not control all the degrees of freedom and a utensil sensor 116 supplies data regarding one or more additional degrees of freedom.

Optionally, one or more feedback providing means 118 are provided on utensil 101. In  
20 one example, utensil 101 includes a vibration applying element or a force applying element for indicating feedback to patient 128 on correct and/or incorrect moves.

In an exemplary embodiment of the invention, system 100 focuses on control and detection of utensil 101. In other embodiments, additional reference points on a patient may be controlled and/or measured. In one example, an elbow brace and movement mechanism (e.g.,  
25 an other limb control 120) may be used to monitor and/or control arm motion during a feeding rehabilitation activity.

In an exemplary embodiment of the invention, utensil 101 is permanently attached to system 100. Optionally, however, system 100 includes a means to rapidly attach and detach utensil 101. In one example the means comprises a rubber coated pincer. In another example,  
30 the means comprises a hollow tube which fits over the handle of the utensil. In another example, a bayonet connection is used for quickly changing utensils. In another example, a ring or sleeve which fits on a finger is used to control the finger of the patient as a utensil.

Optionally, controller 102 is designed for interaction with a user (e.g., patient 128 or a therapist), for example, using a user input device(s) 122 and/or a display(s) 126. Optionally, a



414/04032

link 124 is provided to a remotely located computer, rehabilitation device, database and/or therapist. Controller 102 optionally includes storage for storing results and/or programs for one or more patients.

It should be appreciated that a rehabilitation system in accordance with an exemplary embodiment of the invention does not need to include all the elements shown in the figure. In particular, it should be noted that a wide range of activities can be rehabilitated. In one example, writing, most (or even all) of the motion of the tip of a pen can be in a single plane, and rotation of the pen around its axis may usually be ignored. In another example, eating, both fine and gross motor control are needed and fine motor control is needed over a range of spatial locations (typically at least the plate and the mouth areas).

In an exemplary embodiment of the invention, system 100 is used to control the movements of patient 128, as part of a rehabilitation process. As system 100 includes both sensors and actuators, various movement options may be provided. For example, one or more of the following movement control options may be provided:

- (a) System 100 can prevent unwanted movements.
- (b) System 100 can allow increased patient freedom to pursue movements, as rehabilitation progresses.
- (c) A user can set the freedom level. For example, the movement level can be one of "automatic movement", "user triggered automatic movement", "resistance to user movement", "free movement".
- (d) Movement safety and efficacy, for example, not moving unless the patient is gripping correctly (or at all) the utensil.

Additional possibilities (non-limiting) are described below.

#### EXEMPLARY EMBODIMENT

Fig. 2 is a perspective view of a semi-portable pen-type rehabilitation system 200, in accordance with an exemplary embodiment of the invention. While system 200 could be integrally attached to a table 202, in an exemplary embodiment of the invention, a coupling 204 is used to selectively attach system 200 to table 202. Optionally, this allows system 200 to be attached to a station where a patient is used to carry out his activities and/or wishes to carry out his activities on, for example, a favorite desk or a replica thereof. Optionally, system 200 comprises an extendible arm 206 which can be used to position system 200 so that its active area (e.g., where the rehabilitation activity is carried out) is at a convenient position. Arm 206 is then optionally locked. In other embodiments of the invention, arm 206 is capable of movement, position sensing and/or applying force in a desired manner.

414/04032

At an end of arm 206 and optionally supported thereby is a pen motion mechanism 208 adapted to move, apply force to and/or measure movement of a pen 210. Mechanism 208 is shown in greater detail in Fig. 3. A writing target 212 is also shown, for use with pen 210. An optional sensor 214 may be used, for example for determining a relative position of pen 210, movements of pen 210 and/or for imaging the rehabilitation activity area.

As can be noted, not all the elements of Fig.1 are needed or provided.

#### WRITING SURFACE

Writing target 212 can be of various types. In an exemplary embodiment of the invention, target 212 is a simple sheet of paper. This has the potential benefits of cost, convenience and being natural. Optionally, a pattern, for example a geometric pattern or a written pattern is provided on the paper, to be followed by the patient. Optionally, system 200 forces (or urges) patient 128 to follow the pattern. Alternatively, the system monitors free attempts to follow the pattern. Alternatively, a patient may be forced or urged to follow an invisible pattern, or attempts to follow such a pattern (e.g., pattern described using speech) are monitored.

Optionally, an image source within mechanism 208 is provided for projecting an image on the sheet, for example, projection from under the table or projection from pen moving mechanism 208.

Optionally, pen 210 can elute ink. Alternatively, pen 210 is inert. In some embodiments of the invention, an erasable laminated sheet is used. In some embodiments of the invention, the writing task is performed in the air and not on a surface. Optionally, a hand rest is provided to make the task more realistic, for example a hand rest extending down from pen moving mechanism 208.

In an alternative embodiment of the invention, a tablet device is used, for example, as known for tablet PCs, for PDAs and for stand alone tablets. Many types of pen detection mechanisms are known and can detect, for example, position, pressure, contact and/or pressure of hand on the writing target.

Optionally, the writing target comprises a display for providing a task, feedback and/or instructions. An optional benefit of using the writing target as a display is that patient 128 is generally already looking at the surface, so he is attentive. Optionally, such a tablet device serves as controller 102, optionally using wireless connections.

Optionally, the writing target records the actual material written by patient 128. If motion of the patient's hand is restricted, the writing target may correct for this effect, optionally in real-time so patient 128 can see the results of his efforts during his task.

414/04032

Optionally, the writing target (or other parts of system 200, such as mechanism 208) includes position and/or orientation sensing mechanisms. For example, optical, image based, ultrasound and RF sensing methods are known in the art. Optionally, not only is the location of the pen tip detected, but also the orientation in space, for example using orientation sensors or by detecting the position of the other end of the pen. Optionally, one end is detected by a tablet-like mechanism and the other end from the setting of mechanism 208.

#### PEN

Various types of pens may be used, for example, a plain pen, pencil or marker may be held by mechanism 208. If a tablet mechanism is used, a suitable pen is optionally used. Optionally, the pen includes sensors to sense the contact pressure. Alternatively or additionally, the pen includes grip sensors, for example in the form of an array of pressure sensors distributed on the pen or on special contact points (e.g., three fingers and the area between the thumb and index finger). Optionally, the sensors are provided in a sleeve which can be mounted on an existing pen (or other utensil). Optionally, the pen is designed for a particular patient need; for example, to compensate for hand deformity or limitation in ability to control hand. Optionally, the pen is replaced or modified over time as rehabilitation progresses. Optionally, the pen includes one or more straps or a harness for mounting the pen on the hand (or an artificial prosthesis) of patient 128.

#### PEN MOVING MECHANISM

Various types of mechanisms maybe used for moving pen 210. For example, one of the mechanisms shown in US provisional patent application 60/542,022, the disclosure of which is incorporated herein by reference, may be used. Alternatively, a robotic arm (optionally upside down) may be used.

Depending on the rehabilitation treatment desired, the requirements from mechanism 208 may vary. The requirements may include, for example, sufficiently short response time, ability (and level) to apply force, spatial stability, accuracy and/or precision. For example, one or more of the following rehabilitation-related activities may be provided by mechanism 208:

(a) Moving the hand in a desired manner, as part of a complex motion or a complete complex motion (e.g., to compensate for a non-responsive hand or only for a non-responsive portion). Optionally the system moves the utensil or is otherwise active when detecting the hand is there or responsive to any other command.

(b) Moving the utensil against resistance from the patient. Also, vice versa, the patient moving the utensil against resistance by the system.

414/04032

(c) Nudging the hand in a desired direction, if deemed necessary, or as a reminder that a change in the motion is required. As noted above, vibration sources or other feedback mechanism may be provided in the pen itself. Vibration sources may be point sources, for example activated against a pen contact point with the hand. Alternatively or additionally, the entire pen may vibrate, for example to indicate that a motion is incorrect or that it has been completed and a new motion is expected.

(d) Tracking motion and/or force, for example for diagnosis or to determine what the patient is doing with respect to what is expected or requested. Optionally, when a correct motion is detected, the pen motion mechanism may move the hand in the desired direction, as an assistance.

(e) Damping. Pen 210 may serve to damp tremors in the patient's hand, for example by actively applying a resistive force.

(f) Be able to integrate into real-world activities, such as writing a letter in a manner that patient 128 is used to. Optionally, detecting letters and shapes and preventing moving out of shapes can be used to learn hand writing, even for non-handicapped individuals. However, system 200 may be advantageously used for preventing handicapped children from falling behind in studies.

(g) Correct incorrect hand motions, for example, after a delay, for example, by retracting incorrect motions or by moving the utensil back to a different point on a correct trajectory.

Fig. 3 is an enlargement of mechanism 208 and pen 210, in accordance with an exemplary embodiment of the invention. This motion mechanism includes three functional units, a pen holder 306, a rotary joint 304 and an x-y table 302. Other designs and/or rehabilitation processes can be provided as well, for example as described in the above referenced US provisional application.

Optionally, a camera 344 is provided, to monitor the user movements. In some embodiments of the invention, images captured by camera 344 are used for later analysis. Alternatively or additionally, the camera is used for tracking the pen motion, instead of or in addition to other sensors. In another example, camera 344 is used for tracking the pen position relative to a "dumb" writing target 212 or for calibration of their relative positions. A variety of suitable image processing techniques are known in the art. Optionally, the hand, pen, pen holder and/or writing target are marked for easy automatic identification.

**PEN AND PEN HOLDER**

414/04032

In an exemplary embodiment of the invention, a simple pen holder 306 is provided, for example a hollow tube with an internal narrowing rubber insert. Optionally, a special pen with various interfaces (such as sensors) is used, and these interfaces are electrically supported by pen holder 306.

5           Optionally, holder 306 is spring loaded so that it maintains the tip of pen 210 in contact with writing target 212. Optionally, holder 306 includes a sensor for determining the contact pressure of the pen, for example, to track lifting and pressing of the pen by patient 128. It should be noted that this pressure can be measured as a variation on the pressure caused by the spring. In general, the spring pressure, while not a constant, changes in a known way and/or  
10           can be calculated and/or calibrated for or treated as a slowly varying value. In other embodiments, the pen is attached to the surface, for example using magnetic attraction.

          Optionally, holder 306 includes a linear actuator for moving pen 210 towards and/or away from writing target 212. Many suitable linear actuators are known in the art and may be used.

15           As noted above, pen 210 optionally includes one or more vibration sources 342, which may be local (vibrating only part of the pen or the hand holding the pen) or global (to vibrate the whole pen).

          As noted above, pen 210 may include pressure sensors for determining grip shape and/or pressure, for example one or more linear array of sensors 340.

## 20   **ROTARY JOINT**

          In an exemplary embodiment of the invention, orientation of pen 210 is achieved using a joint which can rotate in space, optionally without twisting around the pen axis. Optionally, twisting is provided by pen holder 306, for example, free twisting, controlled twisting (e.g., using a motor in holder 306) and/or measurement of twisting.

25           In an exemplary embodiment of the invention, joint comprises a ball 346 that is mounted in a ring 348 and from which pen holder 306 extends. A short nub (hidden) extends from ball 346, optionally in a direction opposite holder 306. The nub rides in the slots of two slotted arc elements 332 and 334, which are optionally generally orthogonal to each other. A pair of motor 324 and 326 are each coupled to an arc elements by couplings 328 and 330, for  
30           example a worm-gear coupling.

          Ring 348 is mounted in x-y table 302, for example using a brace 336 and a finger 322 that couples to the motion mechanism of x-y table 302, as described below.

          Motors 324 and 326 may include encoders or separate encoders or other position sensors may be provided (not shown).

414/04032

When setting a pen orientation, controller 102 determines a desired angular setting of ball 346. Motors 324 and 326 rotate arc elements 332 and 334, which, by engaging the short nub at the intersection of their slots, cause ball 346 to rotate relative to ring 348 (which is prevented from rotating).

5           Optionally, ball 346 is balanced for example, the short nub being weighed to counteract the torque caused by pen 210 and holder 306, or by providing a suitable weight inside ball 346.

          Optionally, motors 324 and 326 are neutral, or possibly apply positive feedback, so that a user of pen 210 feels little or no resistance, when such null resistance is desired (e.g.,  
10           during monitoring).

          A universal joint may be provided instead of the above described mechanism.

#### **X-Y TABLE**

          As noted above, joint 304 is optionally mounted on an x-y table 302. In an exemplary embodiment of the invention, x-y table 302 comprises two orthogonal slotted members 318  
15           and 320 which are moved by a pair of motors 310 and 312, optionally coupled thereto by a pair of bands 314 and 316. In an exemplary embodiment of the invention, finger 322 is engaged by the crossing of the slots of slotted members 318 and 320.

          Other x-y table designs are known in the art and may be used.

          It should be noted that in this described embodiment of the invention, many "natural"  
20           pen motions will require a coupling between the motion of ball joint 304 and x-y table 302. In an exemplary embodiment of the invention, such coupling and coordinated motion between the separate motion elements is provided by controller 102.

#### **CALIBRATION AND PROGRAMMING**

          In an exemplary embodiment of the invention, system 200 is calibrated, for example to  
25           determine the relative position of pen 210 and the writing target in a resting position. In an exemplary embodiment of the invention, the pen is positioned in a resting position and an image of the writing target and the pen is acquired. Optionally, the writing target is a display type writing target which can correct its position based on the calibration.

          Optionally, system 200 is programmed, for example using the input 122 and display  
30           126. Optionally, programming is by manipulating utensil 101 in a "learn" mode. In an exemplary embodiment of the invention, a remote link is provided for remote training and/or control of the system.

#### **UNDER TABLE EMBODIMENT**

414/04032

Fig. 4 shows system 400, an alternative embodiment of the invention, in which a pen 402 is held, moved and/or monitored from underneath a table, rather than above it.

In an exemplary embodiment of the invention, pen 402 is mounted on a surface 404, at a point 406. A ball joint 412 (for example like joint 304 of Fig. 3), is coupled to pen 402 via a  
5 rod 408, which, for example, is contiguous with pen 402. Optionally, a spring-loaded base 410 is provided for rod 408, to accommodate changes in the distance between point 406 and all 412. Optionally, pen 402 is axially retractable from rod 408, at least for a short distance, to emulate pen lifting. Tension in pen 402 may be used to indicate lifting force. An actuator may be provided to provide control of such lifting.

10 In an exemplary embodiment of the invention, surface 404 is mounted on a structure 420 which is movable by an x-y table 422, described below.

In an exemplary embodiment of the invention, ball 412 is passively mounted on an x-y table 414, so that changes in orientation of rod 408 (caused by a pair of motors 413 and 415, for example) are translated into x-y movement of ball 412 constrained by two orthogonal  
15 slotted elements 416 and 418. Alternatively, table 422 can compensate for the relative motion of point 406.

In an exemplary embodiment of the invention, x-y table 422 comprises a pair of motors 424 and 430, which move a pair of orthogonal slotted elements 426 and 428, for example using a worm drive.

20 In an exemplary embodiment of the invention, x-y table 422 moves both structure 420 and surface 404. Optionally, patient 128 wears slippery gloves so that this motion will not be bothersome. Alternatively or additionally, x-y table provides motion to compensate for writing motion, so that the motion seems more natural.

In an alternative embodiment of the invention, the size of surface 404 is made small  
25 (so the hand can rest on a table) and/or a non-moving resting area is provided for the hand. In some embodiments, no table is provided at all.

Optionally, a moving (relative or absolute) or fixed image are projected on surface 404.

#### EATING REHABILITATION SYSTEM

Fig. 5 is a perspective view of an eating rehabilitation system 500 in accordance with  
30 an exemplary embodiment of the invention. System 500 includes a table 502 (or system 500 may be adapted for mounting on standard tables, for example including a suitable frame 516). An eating target 504, for example a plate may be fixed to table 502 or may be allowed movement. A utensil 506, for example a spoon is held by a utensil holder 510 which has a fine movement control mechanism 508 associated with it. Mechanism 508 may be the same as

414/04032

mechanism 208 described above. Optionally, additional rotational and/or translation degrees of freedom are provided. For example, holder 510 may include extension and/or rotation. Optionally, some degrees of freedom are only sensed. For example, an orientation of utensil 506 relative to a horizon may be determined using an accelerometer.

5 In an exemplary embodiment of the invention, system 500 can be used to rehabilitate not only fine movements but also gross movements associated with eating. To this end a gross motion mechanism 514 is optionally provided, which adds three degrees of freedom of translation to mechanism 508 by moving a support arm 512 interconnecting them.

10 Optionally, the combination of mechanisms 508 and 514 allows fine motor control to be rehabilitated over multiple spatial locations as may be found in many daily tasks, such as eating, where fine control is required at the plate, at the mouth and to some degree during a trajectory of a spoon.

15 Optionally, motion control at another point on a body, for example an arm, is provided. In an exemplary embodiment of the invention, a robotic arm or other positional controller 518 is used, which includes an arm rest 520. In one example, controller 518 comprises a slotted element mechanism as described above. In another example, controller 518 comprises a ball 522 and an extendible arm 524, each of which may be powered by one or more motors and/or sensed by one or more sensors.

20 In an exemplary embodiment of the invention, mechanism 514 is as follows. A ball 526 is held between two apertured plates 528 and 530. One or more motors 532 move ball 526. An optional brake 534 operates by approximating plates 528 and 530, thereby increasing friction on ball 526. An extending arm may be provided as well.

25 In an exemplary embodiment of the invention, mechanism 508 includes a camera or other sensors to detect proximity to a mouth and/or a state of the mouth. This may be used to assist in training a patient to coordinate the mouth and the hand. Optionally, the camera detects a mouth open condition by providing a marker above and a marker below the mouth, and detecting the distance between the markers. Alternatively, non-marker image processing techniques may be used.

30 In an exemplary embodiment of the invention, system 500 can be used during eating or for feeding the patient. Optionally, any step of the feeding may be temporarily taken over by the patient. Optionally, a pause is interpreted as an opportunity to remind the patient of the next movement, for example using speech feedback or by nudging the utensil in the correct direction.



414/04032

Optionally, a camera 536 is provided to track utensil 506 and detect missing of plate 504 (or a serving dish, not shown), or dropping of food, for example at plate 504, at the mouth and/or onto the patient.

Optionally, other utensils may be attached, or a pair of utensils may be controlled together, for example using multiple fine and/or gross motion mechanism. In one example, a cup is controlled. In another example, a fork and a knife are controlled together. In another example, two chopsticks are controlled together. Optionally, two separate fine motion mechanisms are provided, one for each chopstick. Both fine motion mechanisms are optionally attached to a same gross motion mechanism.

In an exemplary embodiment of the invention, machine replacing of the utensils is supported. In an exemplary embodiment of the invention, the utensil holder comprises a magazine of multiple utensils which may be replaced by machine command. In one example, for children, a plurality of different crayons are provided.

While arm rest 520 is optionally movable, in some embodiments of the invention, rest 520 is used to limit motion of another point of the body. It should be noted that such other point fixation and/or control may be used for other tasks, such as writing.

A particular feature of some embodiments of the invention is that fine motion rehabilitation can require high resolution feedback and/or multiple degrees of freedom in a small volume. In an exemplary embodiment of the invention, one or both of these needs are provided by a fine motion mechanism being placed close to the work volume. Optionally, such a mechanism can also be light and exhibit less resistance and/or delays to motion.

Optionally, the fine motion mechanism is stabilized, for example using a relatively rigid support. Optionally, a dynamic stabilization is provided. In one example, feedback from a camera is used to apply corrective fine motions (e.g., via the x-y table). In another example, the utensil, utensil holder and/or fine motor mechanism includes an accelerometer or other suitable sensor. The input from such a sensors is use to close a feedback loop (optionally using the pen moving mechanisms) which stabilizes the utensil in space, as desired.

#### OPTIONAL ADD-ONS

Systems 100, 200 and 500 may be modified in various ways, for example, using add-on elements. In an exemplary embodiment of the invention, patient 128 wears a glove which provides EMG measurements of the hand. Alternatively or additionally, such a glove electrically stimulates the hand.

Optionally, speech input is provided, for example to allow patient 128 to control the operation of the system using voice control. Optionally, a patient can announce a desired code

414/04032

word or language word which will define a pattern (e.g., the word itself) to be used for a rehabilitation task.

Optionally, various harnesses are used. In one example, for chopsticks, one chopstick is controlled by the system and the other chopstick is attached to the hand using a harness  
5 (e.g., possibly a suitable glove).

Optionally, a finger harness is provided so that the rehabilitation system can manipulate a finger or a part of the hand as if it was a utensil.

It should be noted that system 200 general controls only an end point of the motion (e.g., the utensil). For controlling the motion in greater detail, more points on the limb (e.g.,  
10 using positioning systems as shown in Fig. 5) or motion restricting means, are optionally used.

#### EXEMPLARY SIZES

In an exemplary embodiment of the invention, the fine motion mechanism covers (can move a utensil in) a volume of, for example, less than 30 cm on a side, less than 20 cm on a side or less than 10 cm on a side. Optionally, the volume has a minimal extent of less than 2  
15 cm.

In an exemplary embodiment of the invention, a gross motion mechanism covers a volume of, for example, between 20 and 100 cm on a side. Optionally, the volume is cylindrical, for example with a diameter of 40 cm or less. The axis may be curved.

Optionally, the fine motion mechanism can apply forces of 1 Kg or less. In other  
20 embodiments, greater forces are applied. Optionally, an accuracy of force application of 100 g, 10 g, 1 g or less are provided, in one or more degrees of freedom of the system.

Optionally, the accuracy of utensil tip placement is within 3 mm, 2 mm, 1 mm or less. An angular accuracy is, for example, within 10 degrees, 5 degrees 1 degree, 0.5 degrees or less.

#### 25 USAGE

Various ways of using a rehabilitation system are described in the above provisional application. In particular, it is noted that the systems described herein may be used at home attached to everyday work stations, such as tables and counters. Optionally, the rehabilitation system stores logs, results, activities, plans, progress reports and/or other data, locally.  
30 Alternatively or additionally, some or all of such data is stored remotely.

In an exemplary embodiment of the invention, a network of rehabilitation systems is used for collaborative or competitive activities, for example races.

Optionally, the rehabilitation system is connected to a television set or a virtual reality (VR) set (e.g., goggles), to support immersion of the patient during rehabilitation.

414/04032

In some exemplary embodiment of the invention, the utensil tracked is a free utensil which is used to provide feedback but not apply force.

In an exemplary embodiment of the invention, the rehabilitation system is used for evaluation. Optionally, evaluation includes evaluation for testing progress and/or evaluation  
5 for determining ability to carry out certain everyday activities. Optionally, the results of tests with various handicaps (e.g., utensil designs, force fields, tasks, targets and/or time constraints) are optionally used to assess which type of utensil and/or daily task a patient should use.

Optionally, evaluation is periodic, for example, to assess progress and/or to determine  
10 if a plateau of improvement has been reached. Various valuation methods, for example, screwing a bolt, assembling objects, using scissors, sorting and tower building may be used. Optionally, the rehabilitation system is used, for example, to assist a patient during testing (e.g., determine what residual control a patient has), to apply constraints, to guide, to monitor and/or to remind the patient.

15 Various designs for robots and positioning devices (e.g., hexapods) are known in the art. It should be appreciated that various ones of the statements described herein may be adapted for such robots and/or positioning devices, in accordance with exemplary embodiments of the invention. Alternatively or additionally, software may be provided for such robots and devices for carrying out various of the methods described herein, all in  
20 accordance with exemplary embodiments of the invention.

In some embodiments of the invention, the systems described herein are used for uses other than rehabilitation, for example, task training, testing and/or robotic manipulation.

It will be appreciated that the above described methods of rehabilitation may be varied  
25 in many ways, including, omitting or adding steps, changing the order of steps and the types of devices used. In addition, a multiplicity of various features, both of method and of devices have been described. In some embodiments mainly methods are described, however, also apparatus adapted for performing the methods are considered to be within the scope of the invention. It should be appreciated that different features may be combined in different ways. In particular, not all the features shown above in a particular embodiment are necessary in  
30 every similar embodiment of the invention. Further, combinations of the above features are also considered to be within the scope of some embodiments of the invention. Also within the scope of the invention are kits which include sets of a device, one or more tearing pins, one or more attachments and/or software. Also, within the scope is hardware, software and computer readable-media including such software which is used for carrying out and/or guiding the steps

414/04032

described herein, such as control of arm position and providing feedback. Section headings are provided for assistance in navigation and should not be considered as necessarily limiting the contents of the section. When used in the following claims, the terms "comprises", "includes", "have" and their conjugates mean "including but not limited to". It should also be noted that

5 the device is suitable for both males and female, with male pronouns being used for convenience.

It will be appreciated by a person skilled in the art that the present invention is not limited by what has thus far been described. Rather, the scope of the present invention is limited only by the following claims.

414/04032

**CLAIMS**

1. Apparatus for rehabilitation, comprising:  
5 a utensil adapted to be hand held and manipulated using fingers and be used in a real world task;  
a fine motion mechanism coupled to said utensil and adapted to apply force to said utensil, sufficient to move said utensil.
  
- 10 2. Apparatus for rehabilitation, comprising:  
a utensil;  
a fine motion mechanism adapted to move said utensil in at least three degrees of freedom; and  
15 a gross motion mechanism adapted to move said fine motion mechanism, in at least 2 degrees of freedom.
  
3. Pen rehabilitation apparatus, comprising:  
a surface;  
a pen extending up from the surface; and  
20 a motion mechanism adapted to change the orientation of the pen, under the surface.

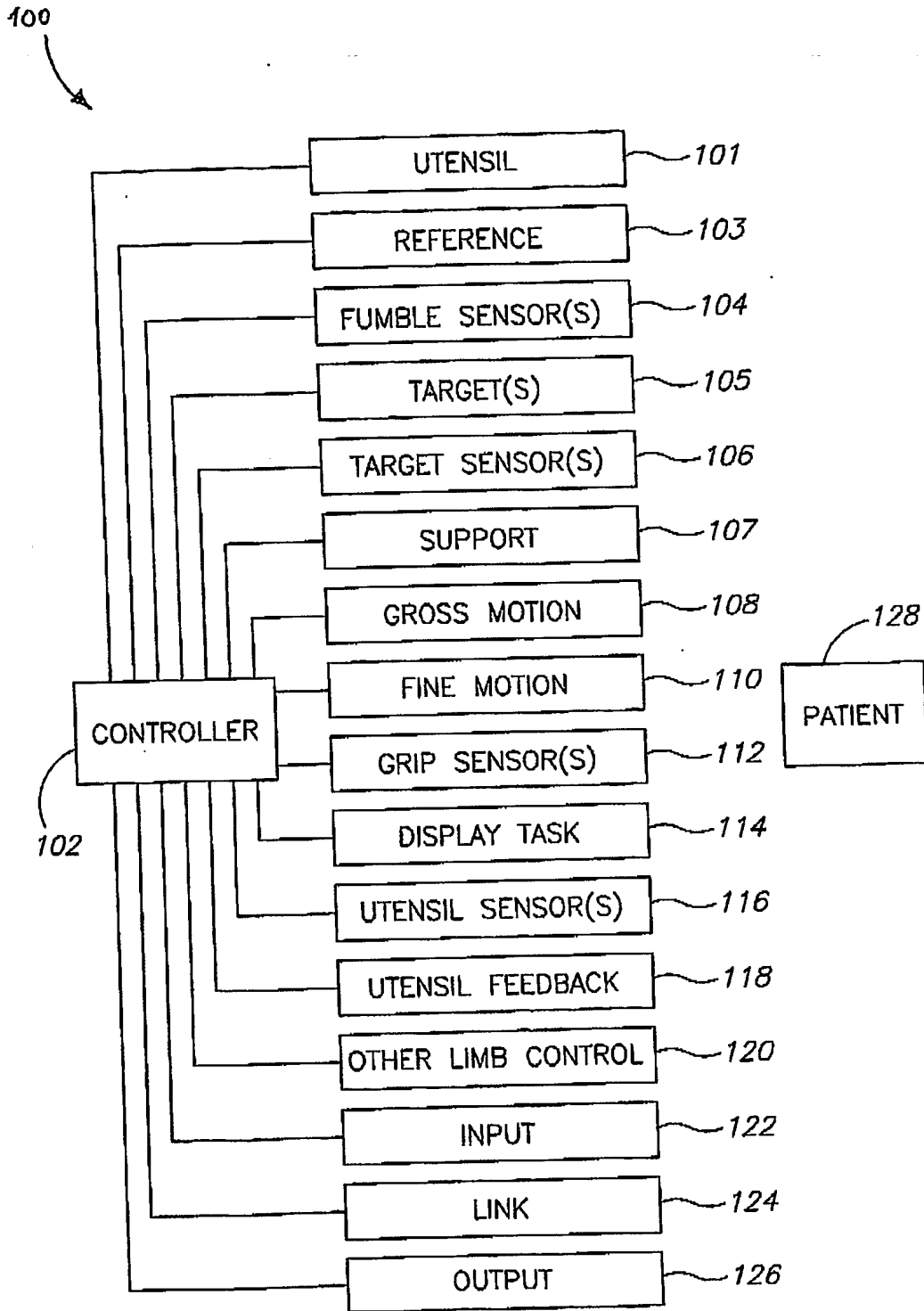

FIG.1

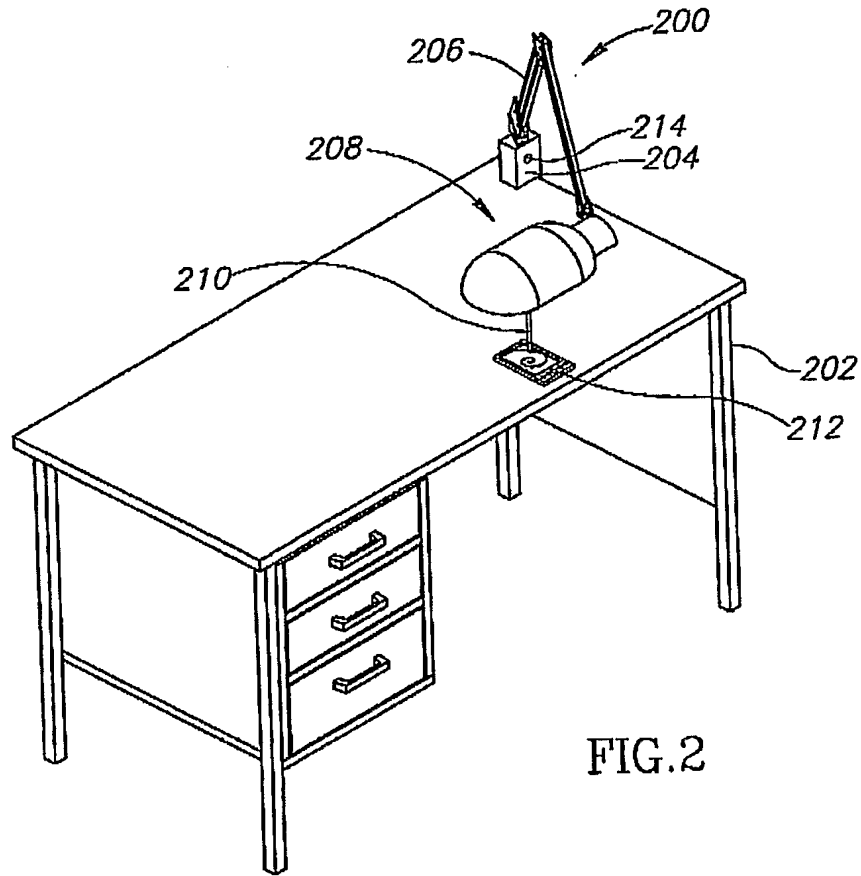

FIG. 2

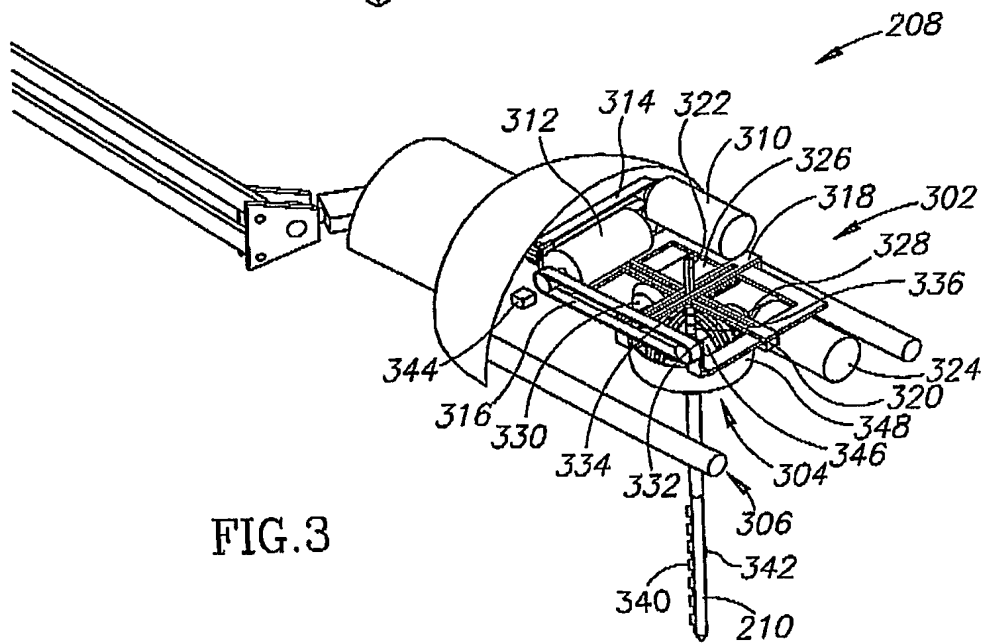

FIG. 3

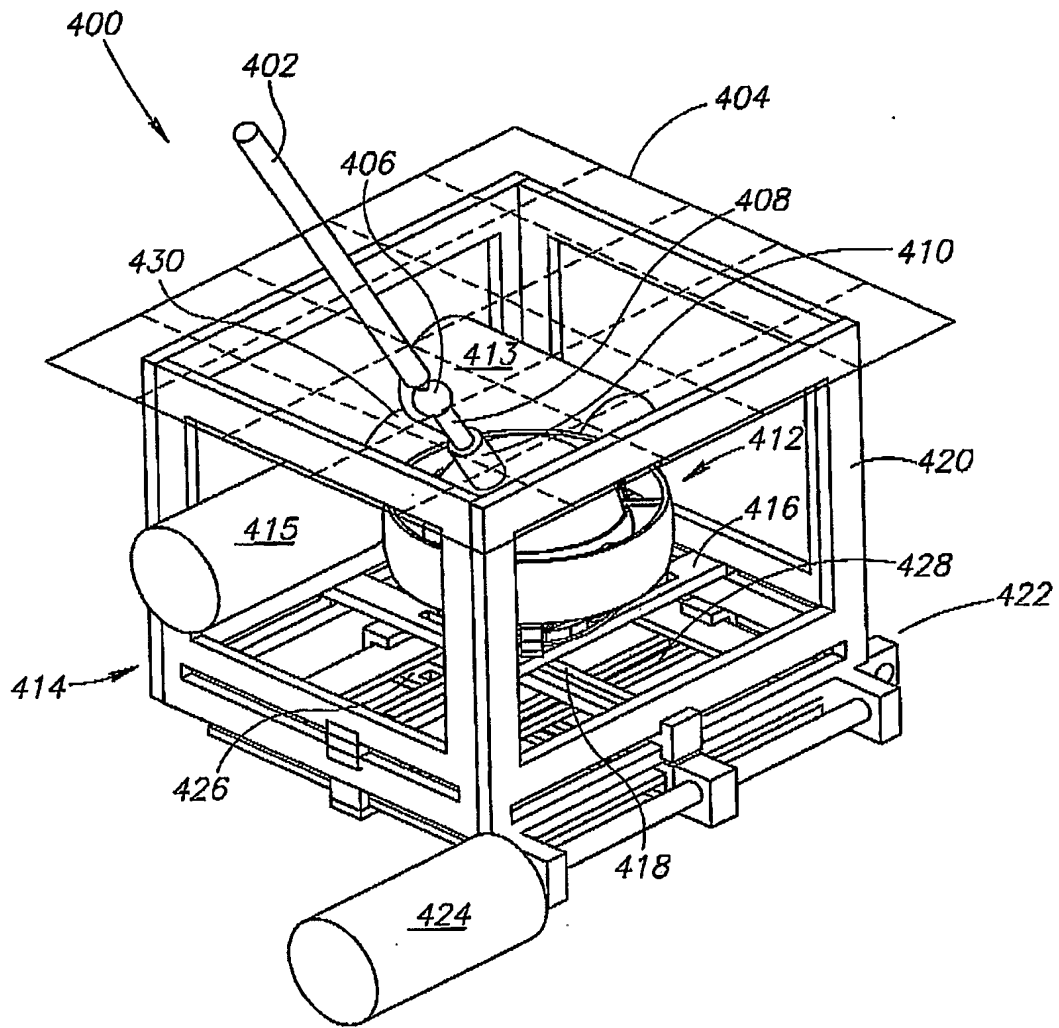

FIG. 4



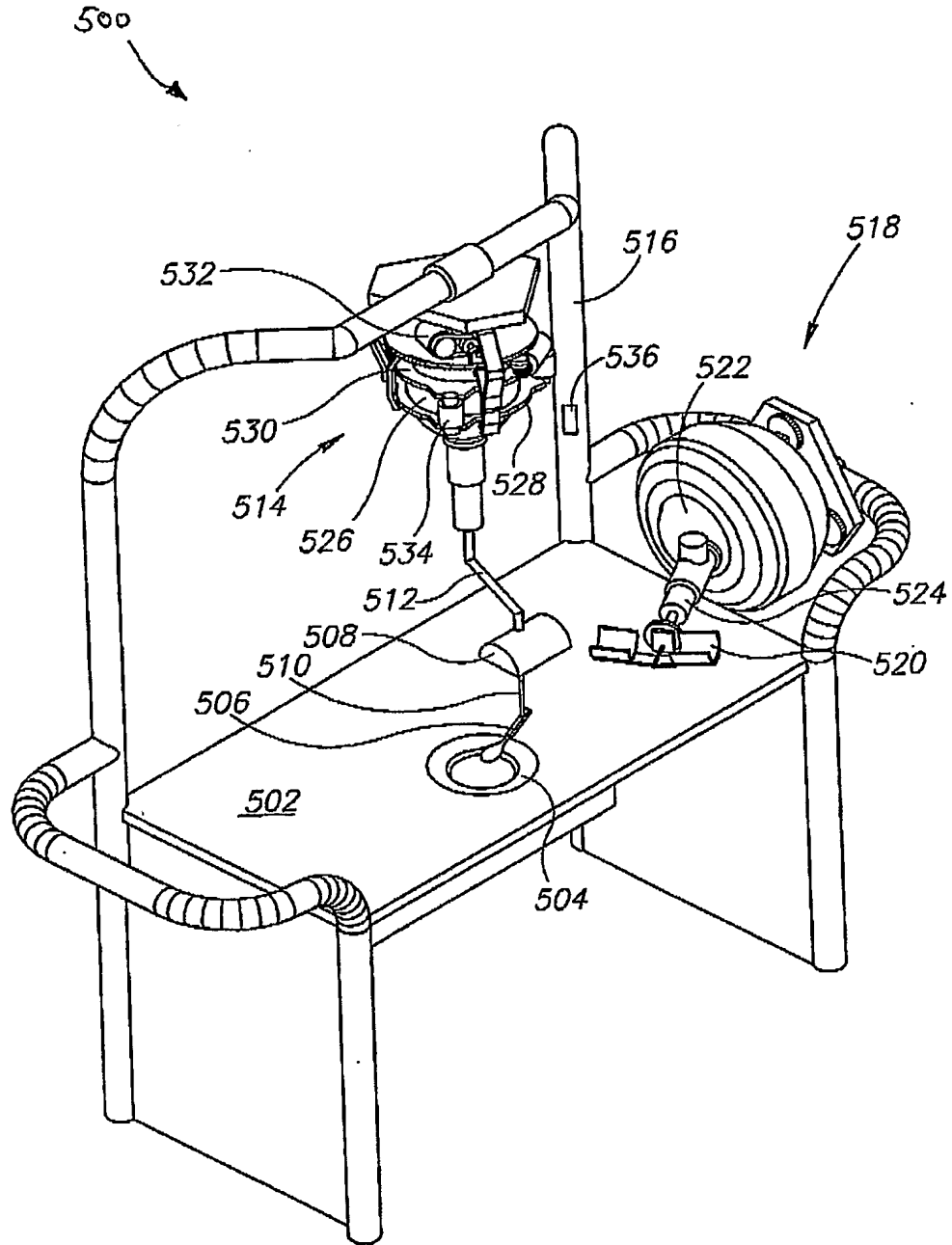

FIG. 5